



## 1. TRANSPORT MODERNISATION VIA CAEV

- A new era for regional transport & manufacture

- Electrification
- Decarbonisation
- Regionalisation





The Veolia commissioned waste vehicle operating in France



## 2. CAEV TECHNOLOGY

- Unique tailoring & construction

- Science & engineering
- Weight, size & performance
- Range & maintenance



Above: The Research Laboratories

Below:

Left - 2 Cylinder engine

Right - 3 Cylinder engine

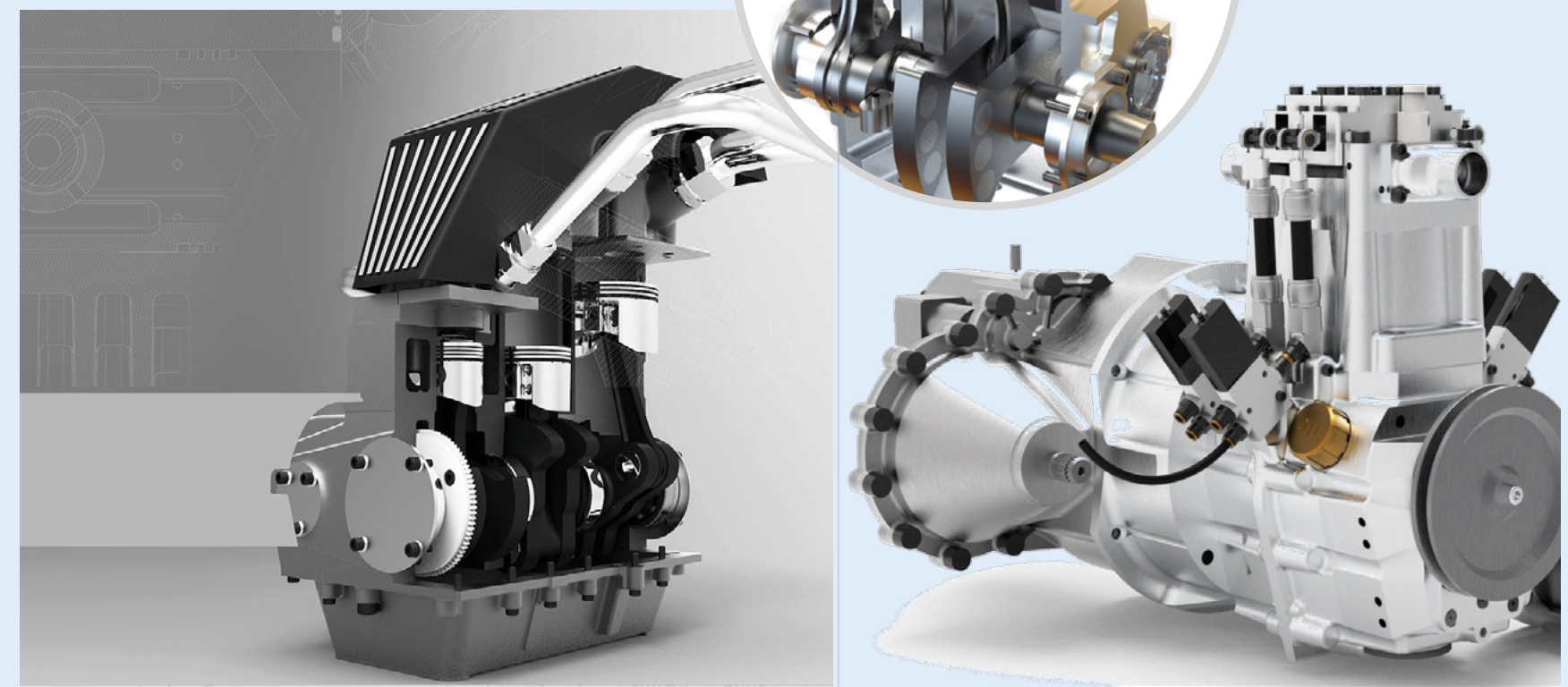



## MCAES/TES MODULARITY SYSTEM

- Energy storage, trigeneration, and vehicle propulsion

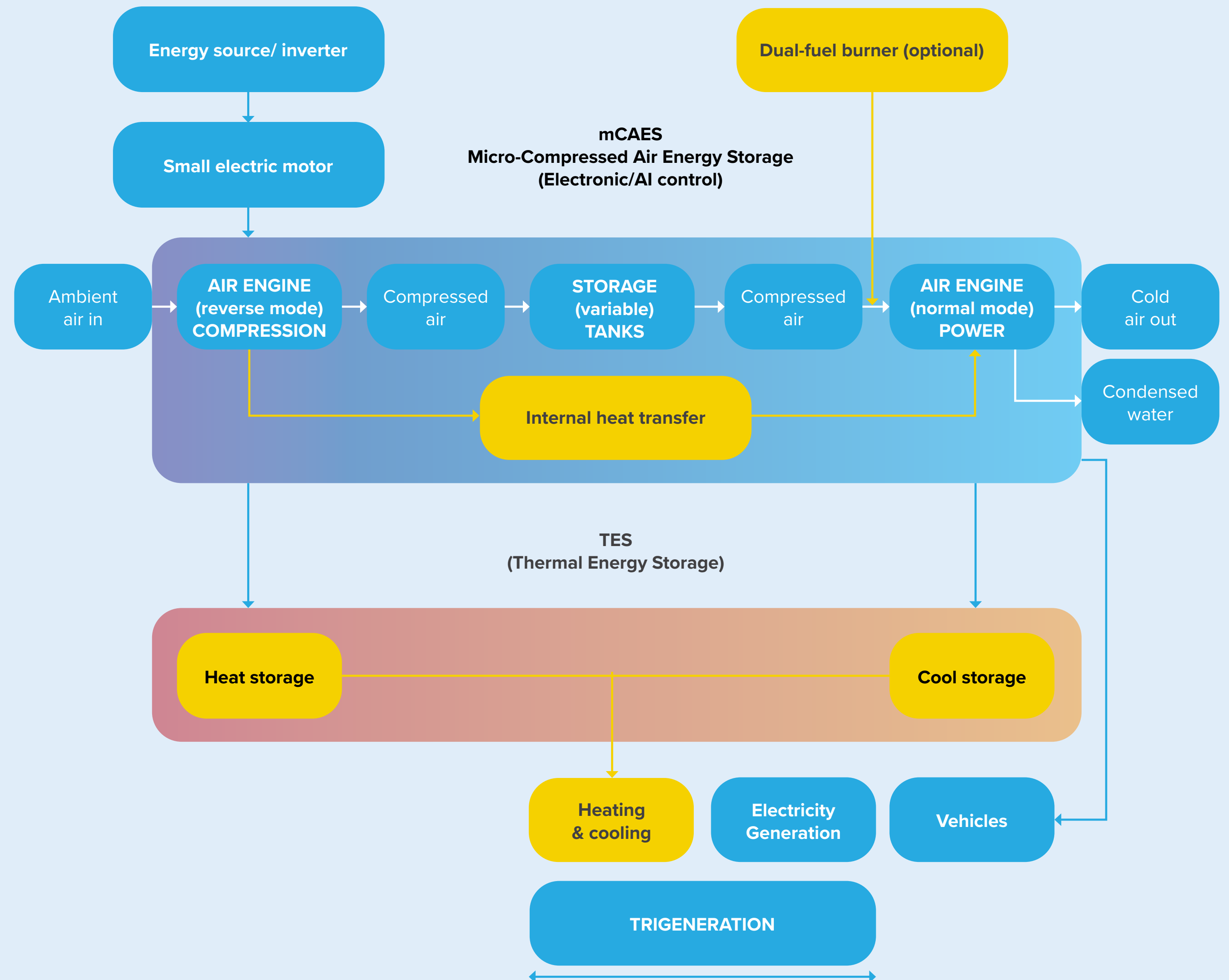



### 3. ELECTRIC VEHICLE CHALLENGES

#### - Transitioning ICE legacy to EV

- The overcapacity legacy
- The lagging markets
- Embedded carbons



**Above:** Hertz is selling 20,000 electric vehicles to buy gasoline cars instead

**Below:** Money should be linked improving regional targets.  
*By 2030 we should be aiming for around 50-60% of new vehicles being EVs*

**Global Spending on the Green Energy Transition Is Climbing**  
Investments surged 17% in 2023

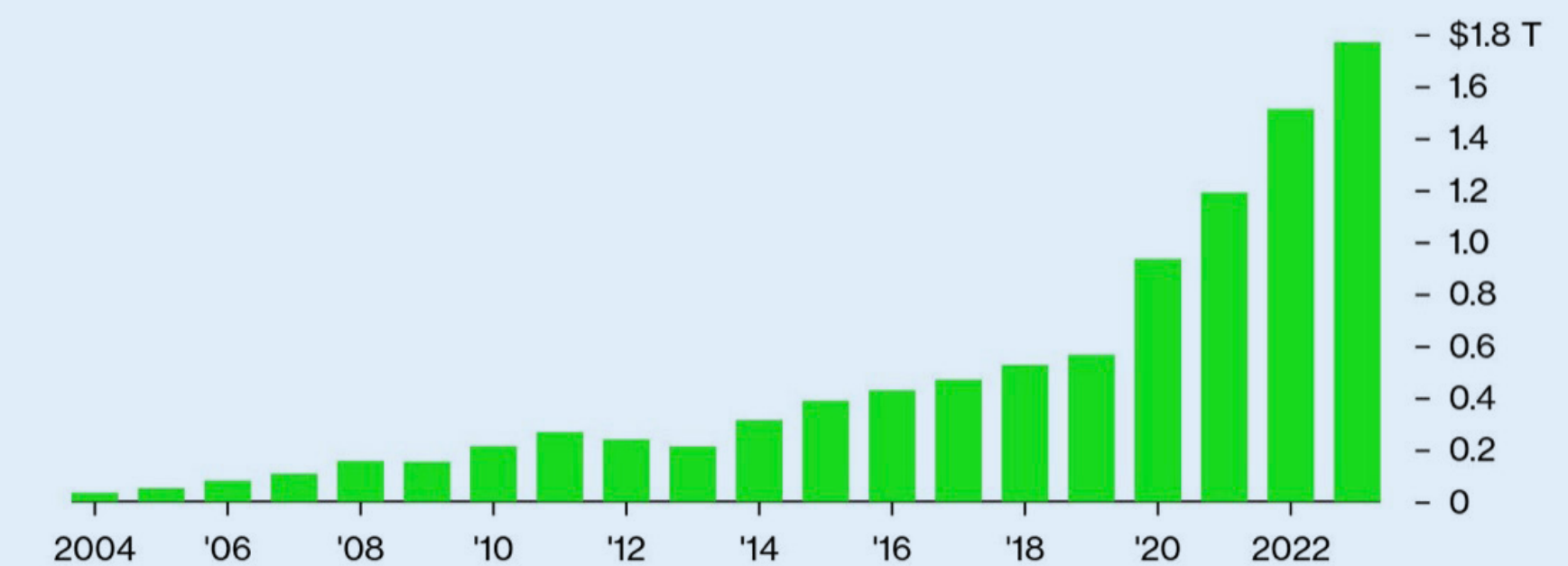

Source: BloombergNEF

Bloomberg Green

Climate embedded carbons from production

# CRADLE-TO-GRAVE LIFE CYCLE OF BATTERIES AND ELECTRIC VEHICLES

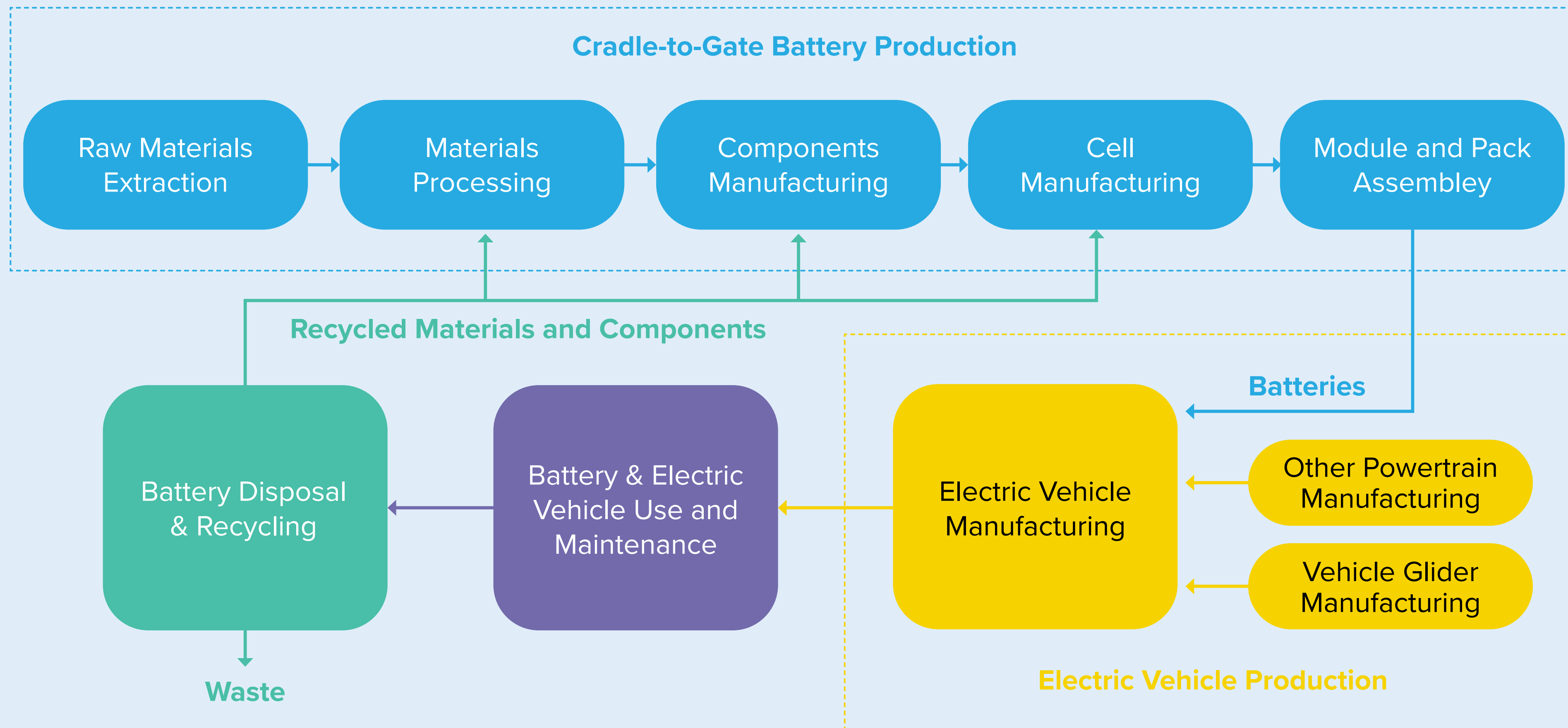



## 4. REGIONAL VEHICLES POTENTIAL

- Tailoring regional vehicles for all

- Matching
- Niches
- Volume

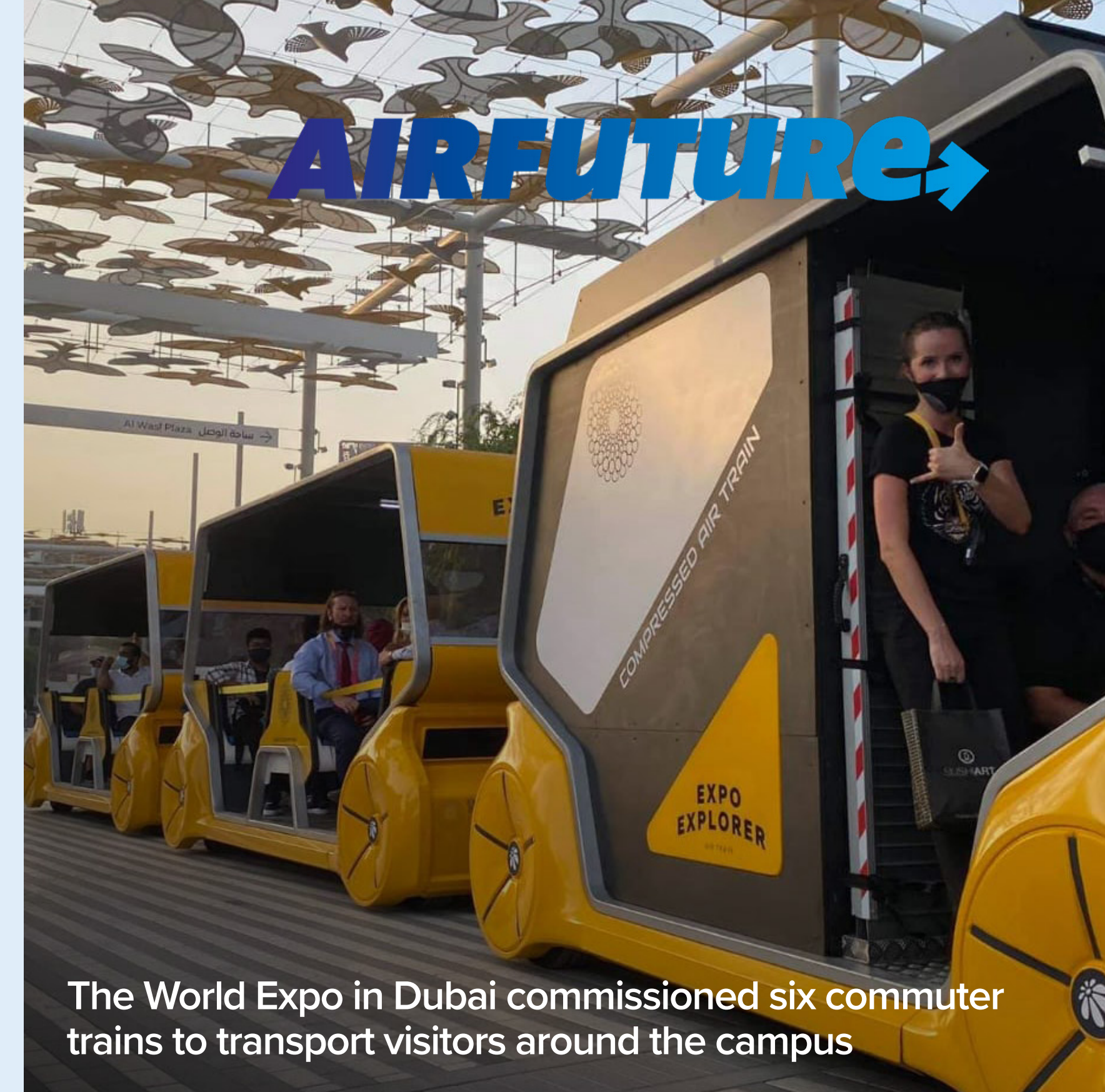

The World Expo in Dubai commissioned six commuter trains to transport visitors around the campus



Assisted by the AirTrain design, ready for mass market applications



Flexible refill designs for very fast refill,  
plus EV charging networks intended.





## 5. DISTRIBUTED & REGIONAL MANUFACTURE

- Ownership & benefits to the regions

- Outsourcing manufacture
- Factory manufacture
- Regional industry

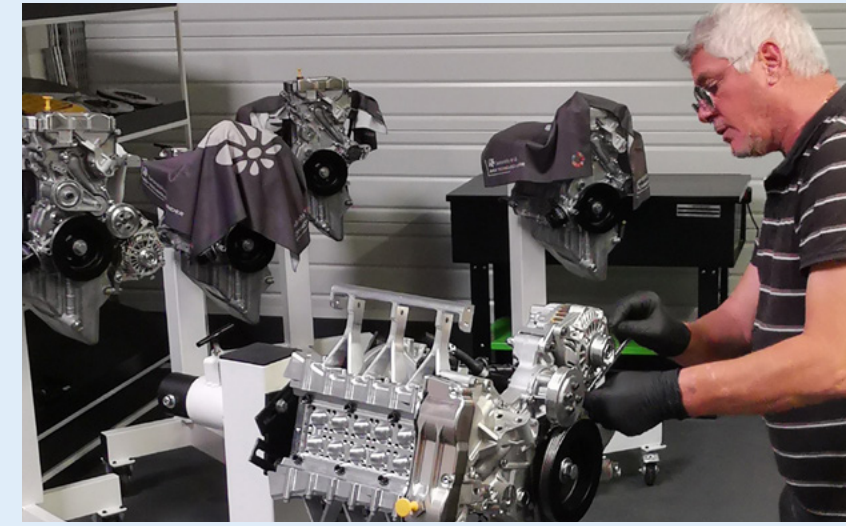
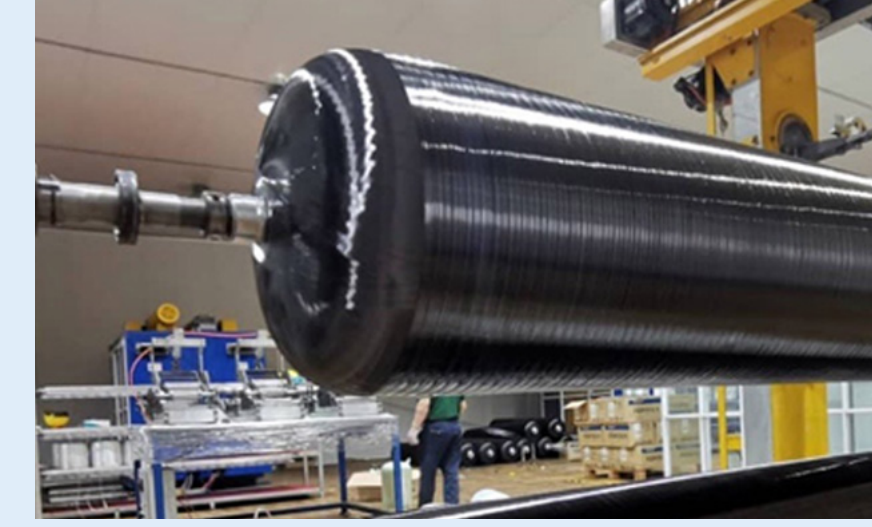
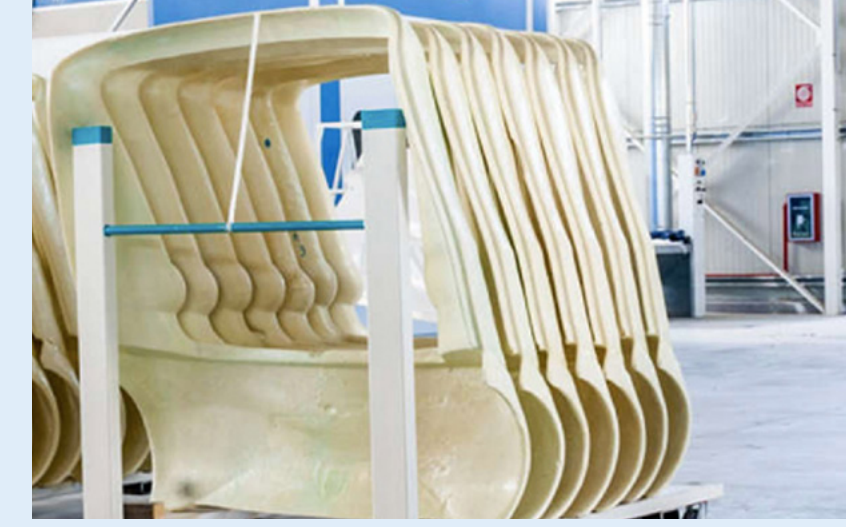

Above: Parts & GreenAir manufacture.

Below: Early development factory on open day



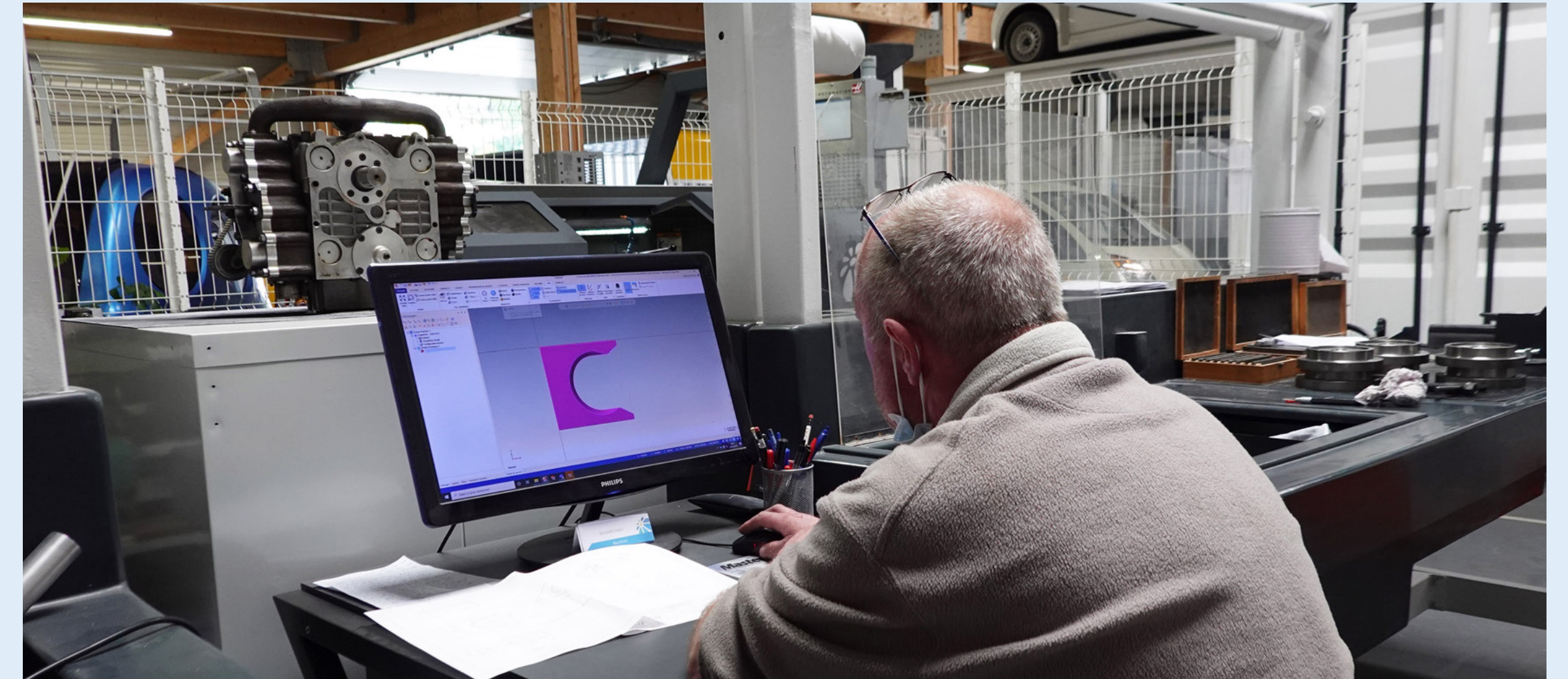

Outsourced manufacture for AirTrain.

## 6. AUSTRALASIAN SHOWCASE & GLOBAL REPLICATION

### - Sponsoring new renewables industries

- Resources & projects
- Replicability & adaptability
- Distributed regional resources

#### Business resources structure for speedy traction

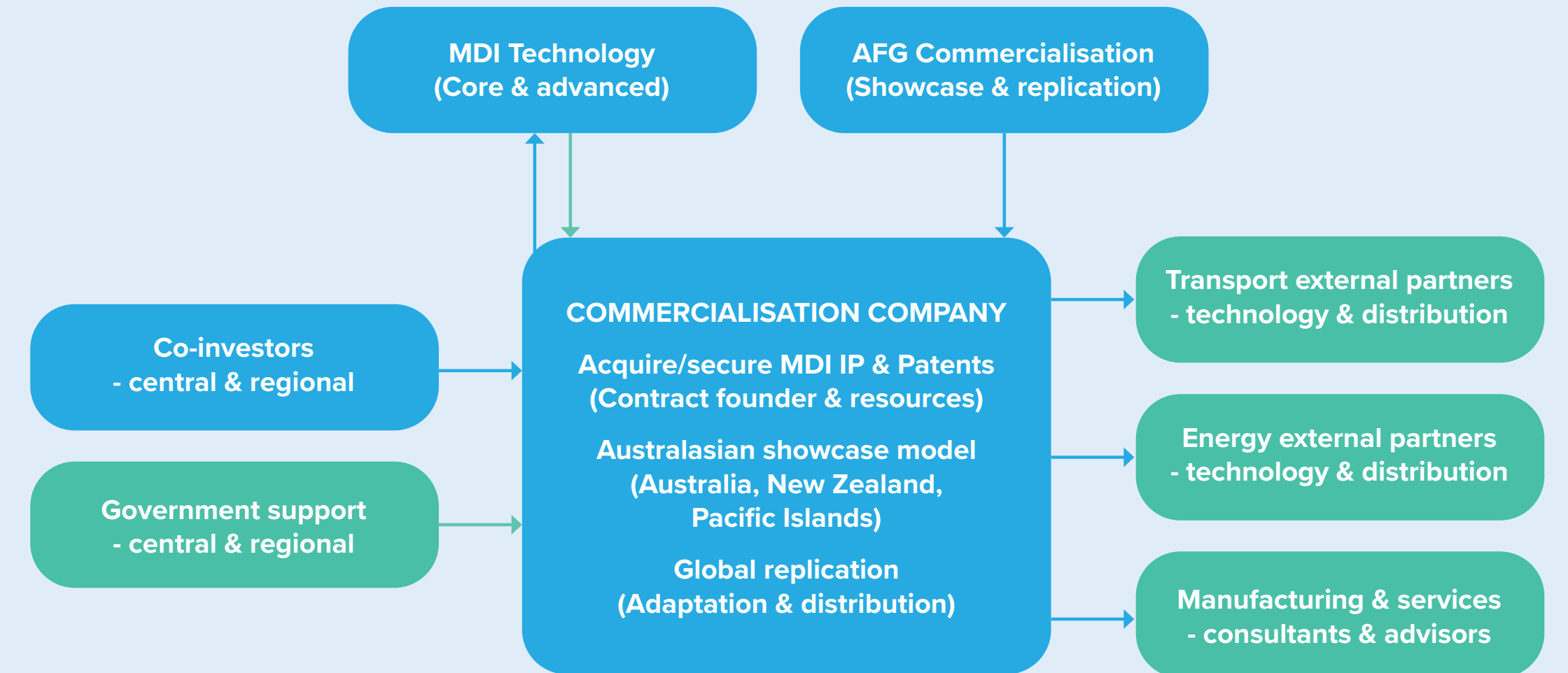

The huge flexibility for cleaning transport.

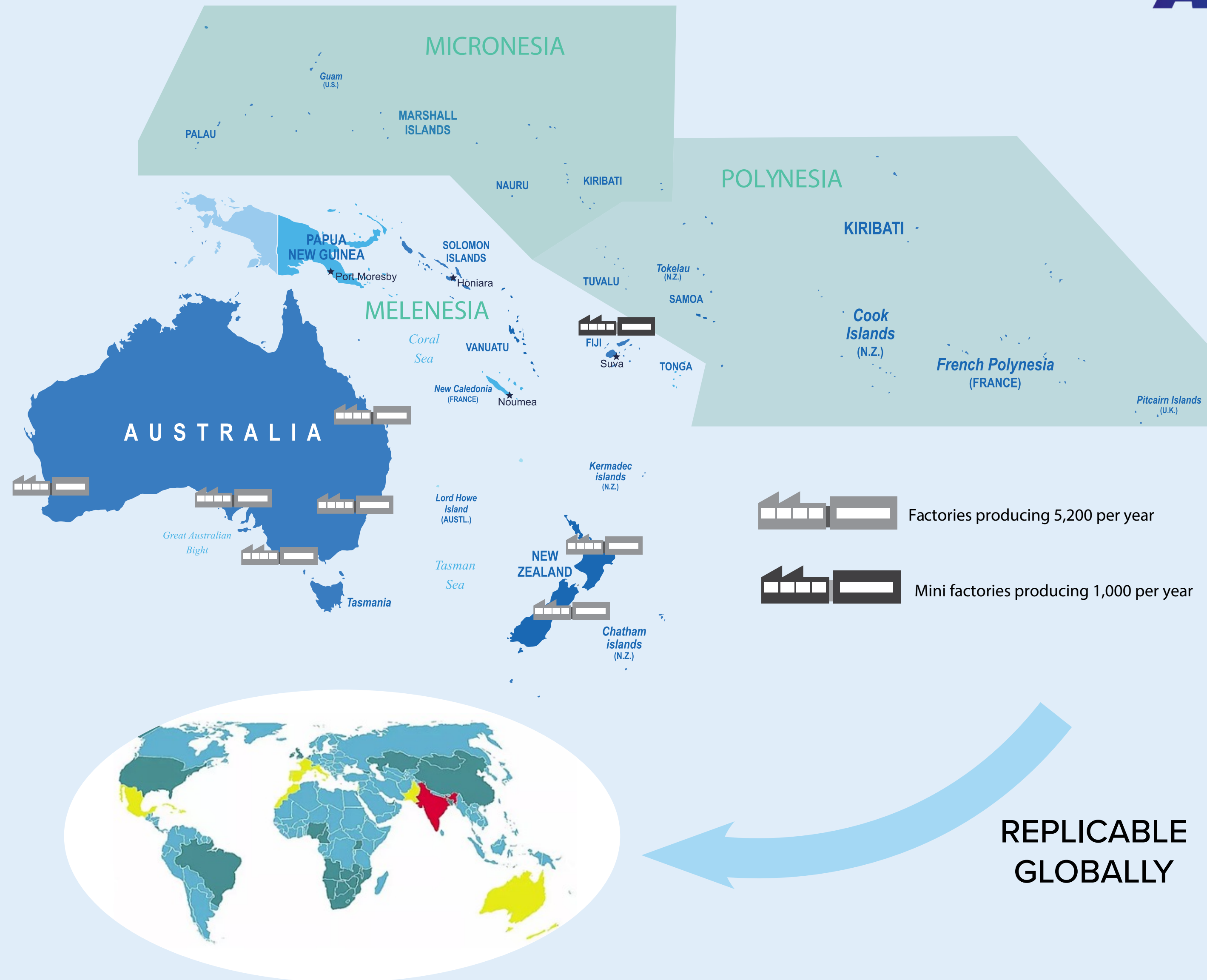

The huge opportunity for Australasia as a global showcase

## THE AIR FUTURE & MDI EXECUTIVES IN THEIR EUROPEAN COMMERCIAL WORKSHOPS.



Above: Australian AFG & European MDI in France planning the Australasian showcase.



Above: Chairman Russell Fitts at the wheel of the later CAEV development model AirPod 2.0



Above: CEO John Mennega driving early CAEV on MDI test track in France